



better together

Data sheet DRG 750/2/80 A0FT5

GREY
series

Technical specification

3~ 50 Hz

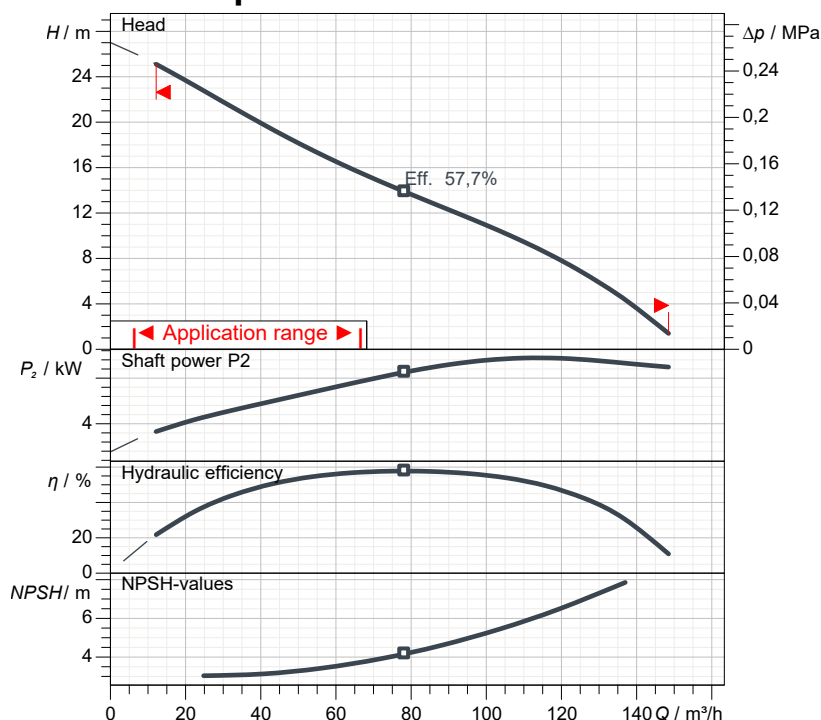

Characteristic curves according to UNI EN ISO 9906:2012
P2 < 10kW: paragraph 4.4.2
10kW < P2 < 100kW: Grade 3B
P2 > 100kW: Grade 2B

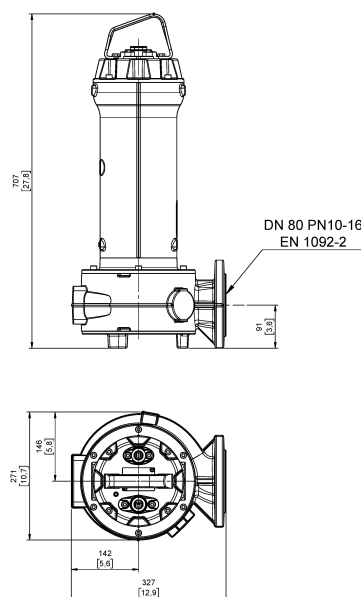

[mm [inch]

Pump

Series	GREY series
Pump name	DRG 750/2/80 A0FT5
Configuration	NGTSB51040N00NN
Standard	CE

Operating limits (standard pumps)

Max. ambient temperature	40 °C
Max. density treated liquid	1.100 kg/m³
pH treated liquid	6 ÷ 14
Max. start per hour (equally distributed)	30
Wet/dry use	WET
Max. acoustic pressure level	70 dB
Operating mode	S1 - Continuous use

Motor data

Rated voltage	400 V
Frequency	50 Hz
Motor phases	3~
Number of poles	2
Rated power P2	5,50 kW
Incoming power P1	6,32 kW
Rated current	10,8 A
rpm	2866 1/min
Efficiency	87 %
cos φ	0,845
Rated torque	18,3 Nm
Start	Direct starting
Starting current	77,8 A
Degree of protection	IP 68
Insulation class	H
Capacitor	
Starting Capacitor	

Construction materials

Case	Cast iron EN-GJL 250
Shaft	Stainless steel AISI 431
Hydraulic	Cast iron EN-GJL 250
Impeller	Cast iron EN-GJL 250
Painting/Coating	Bi-epoxy 200 μm sea water
Screws	Stainless steel - Class A2-70
Gaskets	NBR

Construction features

Cooling system	No cooling jacket
Main cable	4G1,5 + 3x1
Cable length	10 mt
Mechanical seals	2 in silicon carbide (2SiC)
Additional drilling	-
Weight*	71,3 kg
Electrical variant	Thermal protection and leakage sensor

* cable and fixing system excluded

Hydraulic

Free passage	40 mm
Impeller type	Open channel impeller
Max. hydraulic efficiency	57,7 %
Suction	DN 80 UNDRILLED
Discharge	DN 80 EN 1092-2



better together

Data sheet DRG 750/2/80 A0FT5

GREY
series

Pump performance curves

3~ 50 Hz

Impeller type Open channel impeller		Free passage 40 mm	Discharge DN 80	Suction DN 80
DUTY POINT				
Flow	Head	Shaft power P2	Hydraulic efficiency	Density 998,3 kg/m ³
				Viscosity 1,005 mm ² /s

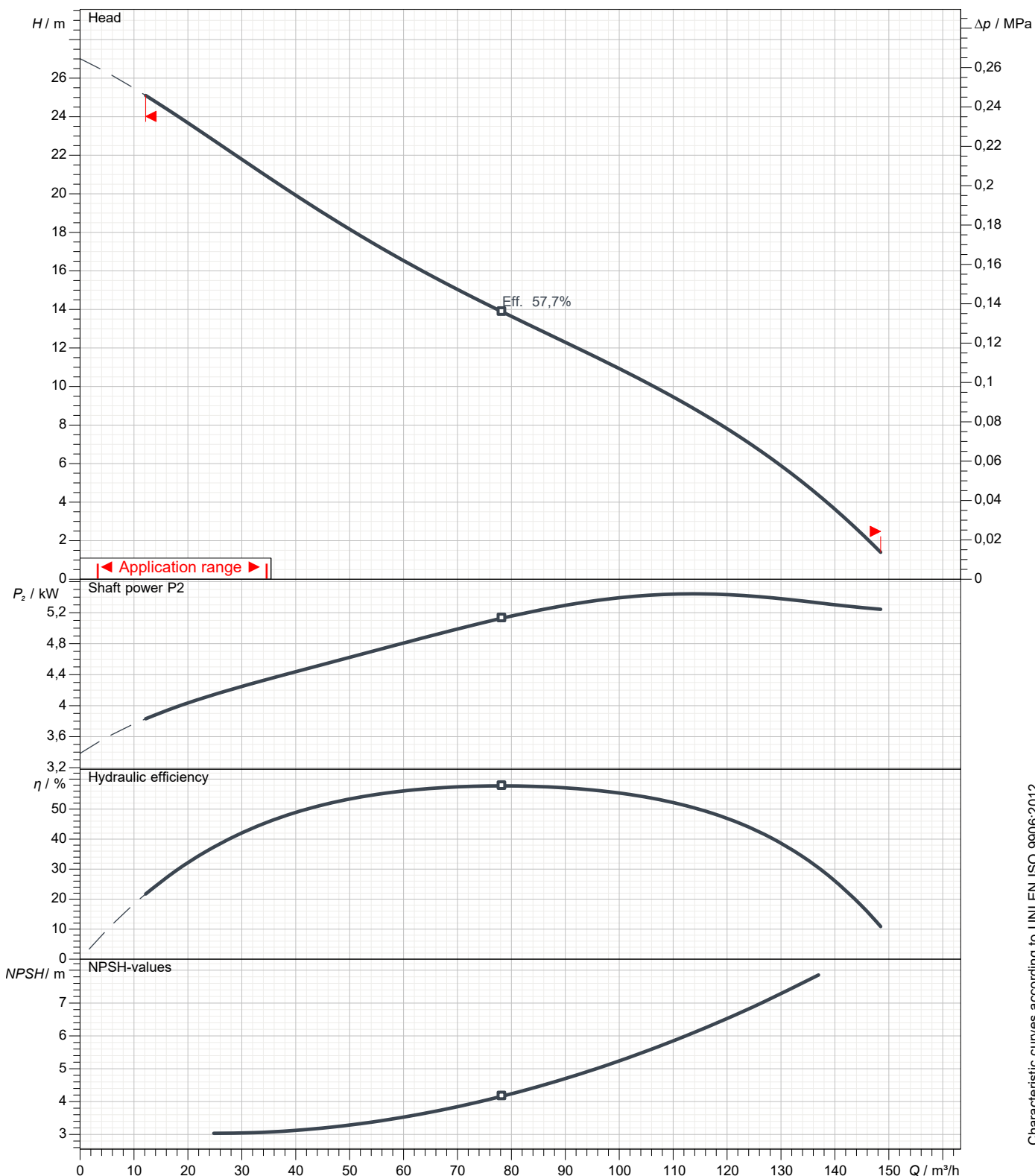

Characteristic curves according to UNI EN ISO 9906:2012
P2<10kW: paragraph 4.4.2
10kW<P2<100kW: Grade 3B
P2>100kW: Grade 2B



better together

Data sheet DRG 750/2/80 A0FT5

GREY
series

Dimensional drawing

3~ 50 Hz

Installation type Installation with bottom coupling device - Vertical outlet		
Wet/dry use WET	Drilling variant N	Flushing valve - drilling -
Discharge DN 80 EN 1092-2	Suction DN 80 UNDRILLED	Pressure rating (suction/discharge): -/PN 10
Accessory DAC 80/80V+KAF 116-2" EN (P)		Accessory code 9001.032
Note: Accessory must be ordered separately		

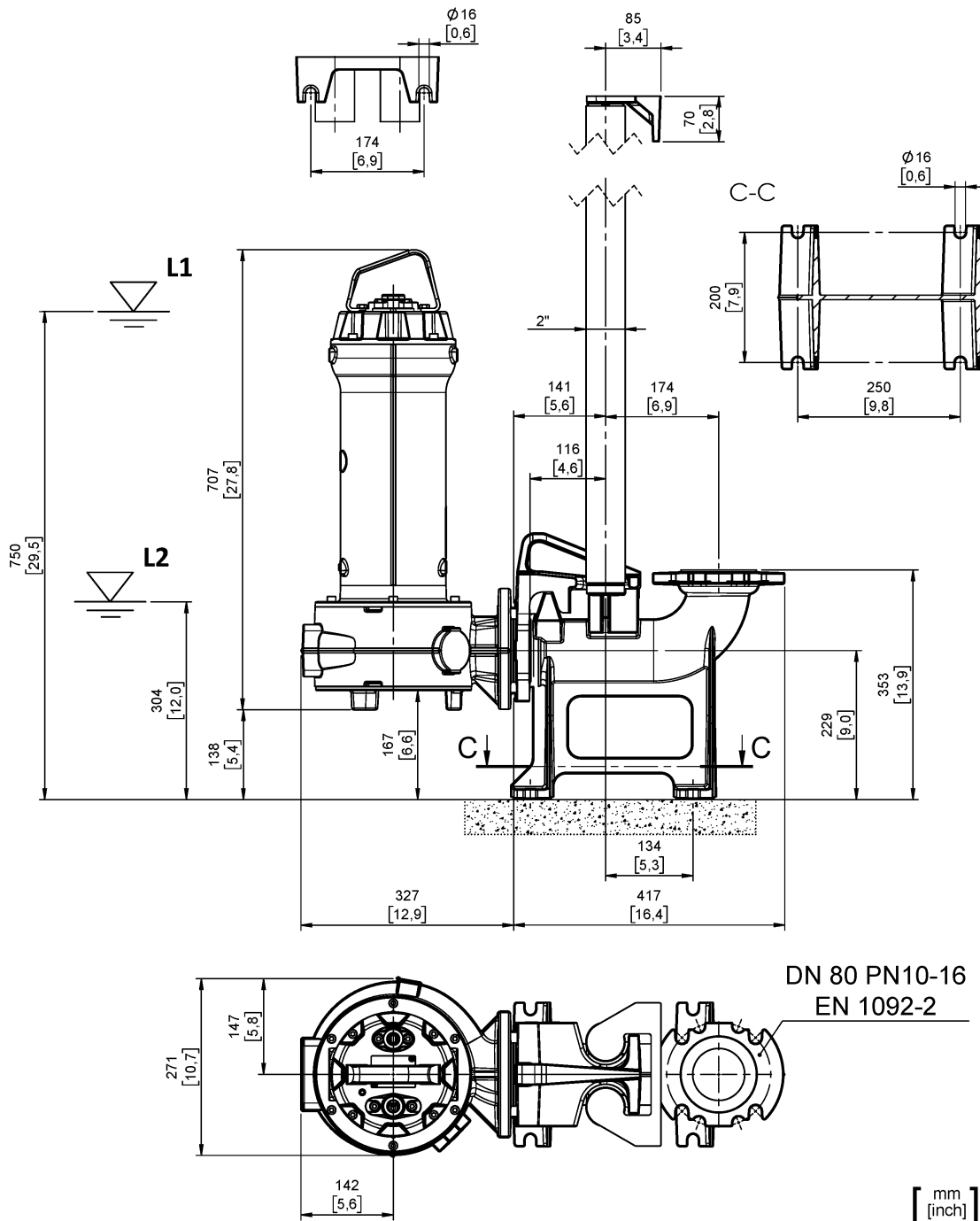

L1: Minimum operating level for continuous use

L2: Minimum operating level for discontinuous use (excluding -EX/FM models)